

# STATIONARY INSTALLATIONS - WHY COMPROMISE

*for every cleaning demand*

**Gerni**  
- danish cleaning power



# Powerful, Flexible and I



## Pressure washers

*The stationary pressure washer range contains both hot and cold water solutions, with a complete range of accessories to improve the handling of most assignments.*

# Easy to Use

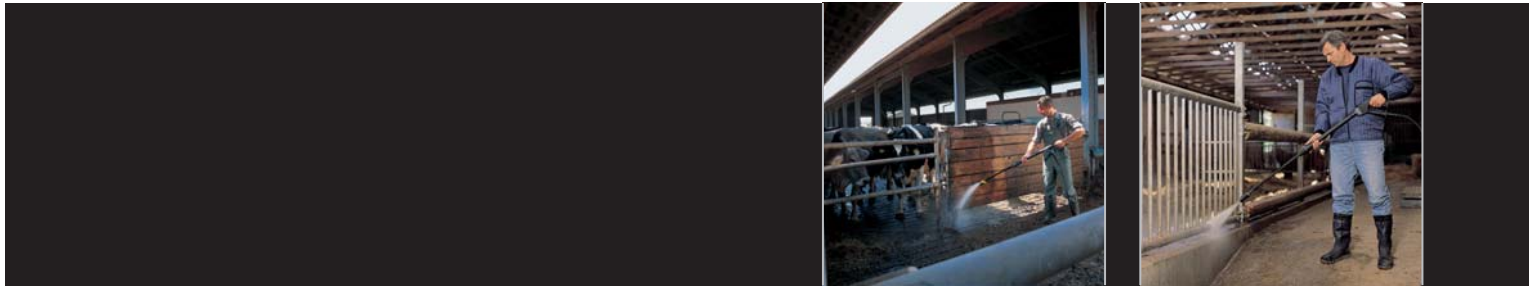

## Stationary installations are the answer to your cleaning needs

You may be interested in **maintaining** hygiene levels in a slaughterhouse, kitchen or processing plant.

You may be interested in **degreasing** metal components in an industrial site.

You may be interested in **adding the final cleaning touch** to vehicles at the end of the production process.

But you are definitely also interested in **rationalising** your cleaning process.

Gerni stationary pressure washers can help you do just that!

Machines can easily be installed in any location around the site. A carefully planned and optimised piping system will then ensure that you can easily and quickly clean in any area of your installation.

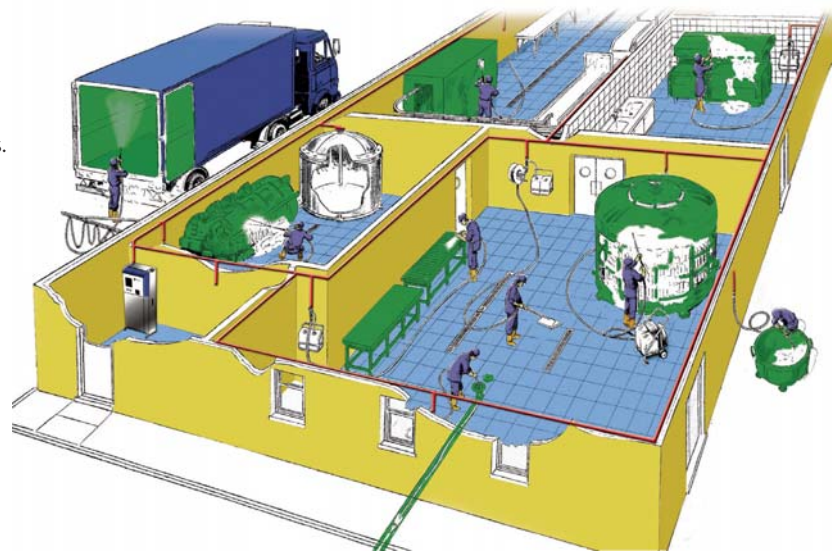

## Stationary units offer numerous advantages

- Units are pre-set for your own needs. Individual users do not need to modify the settings, reducing the risk of error and reducing necessary training time of personnel.
- No need to transport machines from one end of the site to the other.
- No need to purchase several mobile machines to fulfil all cleaning applications.
- The placing of an outlet hose/lance/accessories at each cleaning point means that each user can be operational in seconds, reducing preparation time and labour costs.
- When using pressure washers, chemicals can be applied directly at each site, avoiding transport of detergents manually or through pipes.
- Careful planning can mean that for one machine, up to 6 people can work at any given time.

# Speed up your Cleaning



## The connect and clean Gerni ALPHA BOOSTER range – best in class cleaning at its most simple.

Stationary units are easy to use, save time and money and reduce storage needs :

- Compact, wall mounted design eases storage.
- The unit can be connected to piping system with several outlet points for cleaning in a multitude of sites.
- Reduced need for electrical connections, transport of cable and machine: the unit is immediately available for use – simply connect the hose and clean.
- Extra Hygiene: A stationary unit does not need to be in proximity to the cleaning site, ensuring a higher level of hygiene for example in milk-sheds and stables.

Reduced installation requirements means saving time: you go straight to cleaning and get the job done as quickly as possible.

The Gerni ALPHA BOOSTER is a complete range of 1 and 3 phase mid range units for cleaning in milk sheds, around small farms and garages or also in butcheries and bakeries (for example in supermarkets). It can also be used around swimming pool areas or for any general cleaning tasks that occur in a fixed site.

- 1450 rpm motor pump units for long life and low noise level
- Complete spray equipment as standard accessories – product is ready to use
- Stainless steel cabinet (ALPHA BOOSTER 5) is easy to clean, maintaining hygiene levels in your surroundings.



Gerni ALPHA BOOSTER

The Gerni ALPHA BOOSTER can be equipped with a wide range of accessories for floor, surface and equipment cleaning – please consult our catalogue.

# Tasks



## Technical data

		ALPHA BOOSTER 3-26 107361190	ALPHA BOOSTER 5-49 107361290
Pressure	bar/MPa	135/13,5	180/18
Cleaning impact	kg/Force	2.6	4.9
Water flow - QIEC	l/h	570	900
Water flow - Qmax	l/h	600	970
Max. inlet temp.	°C	40	40
Power consumption	kW	3.3	6.9
	V~/Hz/A	240/1/50/15	400/3/50/12.5
Pump	RPM	1450	1450
Weight	kg	39	48
Dimensions L x W x H	mm	560 x 350 x 370	643 x 357 x 365
Cable	m	5	5

## Standard Equipment:

Hose	m/Ø	10/DN6	10/DN8
Ergo Gun		● Ergo 1000	● Ergo 1000
FlexoPower 3000 lance (92 cm)		●	●
Detergent injection low pressure		●	●
Cabinet		Option	●
Nozzle size		0370	0500
Full ceramic pistons		●	●



The ALPHA BOOSTER 5 can also be equipped with an electronics control box that enables the product to be used with remote controls, coin boxes and 1 or 2, electronically activated detergents

# Flexible, Reliable and always ready to go

– just Connect & Clean



The Gerni DUO BOOSTER 2 pump high pressure cleaning unit is suitable for some of the most intense applications you can find. Assuring regular day to day cleaning often for more than 8 hours, the Gerni DUO BOOSTERS are reliable partners in eliminating tough dirt in the industrial sector and maintaining hygiene levels in agriculture, food industry or simply in industry and construction.

## General information for Gerni DUO BOOSTER

- Stainless steel cabinet is easy to clean maintaining hygiene levels in your surroundings.
- Servicing is easy thanks to the easy access construction.
- Easy to use, single start/stop button – just switch on and clean.
- Stationary products require no transport. Ideal for sites where cleaning is always in the same place. Just attach the hose and clean.
- Low water security function.

## Technical data:

		DUO BOOSTER 107340390
Pump pressure	bar	160
	MPa	16
Water flow (Q <sub>max</sub> /Q <sub>IEC</sub> )	l/h	2400/2240-1120
	l/h	1120
Cleaning impact	kg/Force	11.4
Noise level	dB(A)	79
Max inlet temp.	°C	40
Power consumption	kW	13.5
	V/~/Hz/A	400/3/50/24
Weight	kg	160
Dimensions L x W x H	mm	370 x 800 x 900



### Gerni DUO BOOSTER: ►

For 1 or 2 user applications.

The 3 stage on-off button enables one user to operate with the capacity of 1 or 2 pumps (up to 2400 l/h) or two users simultaneously with the capacity of 1 pump each.

Gerni DUO BOOSTER

# start

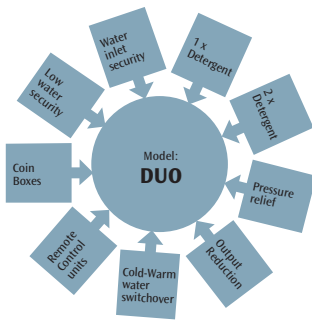
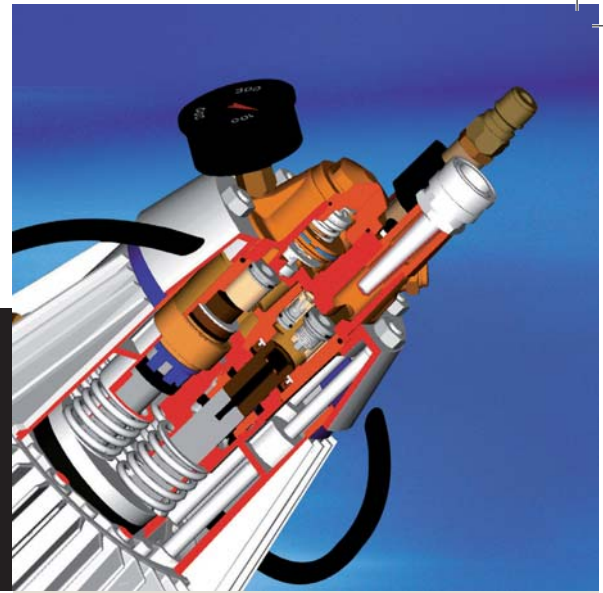

Gerni offers personalised solutions. Each DUO machine can be produced as standard, or be equipped directly from the factory with a range of options to match your specific needs.

### Standard equipment: DUO BOOSTER

Cable length	m	4
Automatic standby		●
Ceramic pistons		●
Stainless steel cabinet		●

## C3 quality PUMP

The famous C3 pump with 4 ceramic pistons and 1450 rpm motor has an exceptionally long working life.

Through the last 20 years it has proven itself to be the most reliable and durable pump on the market, designed to tackle heavy duty applications day after day.

- Ceramic pistons and fibre reinforced seals
- Stainless steel valves
- Brass cylinder head
- Closed oil-system – No refill required as no oil waste – only oil change at service.
- Integrated filter in the pumphead prevents dirt entering the pump
- Visual oil inspection from outside the cabinet
- Integrated flow sensor – dry run protection
- Powerful integrated motor with double thermo sensors
- Robust and simple – no user interactions needed



# The Ultimate Solution



## ▲ Durable stainless steel construction

To meet with industry requirements for a long and effective working life, the cabinet, frame, water tank and the water passage are constructed from highly durable stainless steel and other non-corrosive materials.

## ▲ Water tank

The water tank has both hot and cold water inlets, ensuring that the optimum, pre-set temperature is available at the commencement of cleaning operations.

The Gerni DELTA BOOSTER is a unique cleaning system designed for use in all industrial environments. Capable of up to six operators simultaneous operation, the Gerni DELTA BOOSTER has been developed to fully meet the cleaning demands of industry. Built with hygiene in mind, and with a host of features offering, for example, the flexibility of customised control as well as selectable water volume and pressure.

## ▶ Designed with hygiene in mind

The cabinet is constructed with large, easy-to-clean surfaces that will not harbour dirt in corners or crevices.

## ▼ Compact, space saving design

Because room is often at a premium - especially in confined areas, the Gerni DELTA BOOSTER has been designed to use as little space as possible. This compact design also allows easy transportation and installation.



## ▼ Optional mounting

In order to meet individual installation requirements, the water tank and inlet connections can be built, to suit the left or the right hand.







### ► Lances

Different cleaning tasks require different applications of water volume and pressure. Utilisation of the colour coded lances will ensure that you deliver the correct volume and pressure to efficiently complete the task at hand.



### ► Pump - The heart of the machine

The Gerni DELTA BOOSTER is fitted with the unique C3 piston pump. The pump features a pressurised sealed oil chamber, which virtually eliminates oil waste.



### ► Control

Individual control requirements vary. The control system is readily adaptable to suit particular circumstances, offering for instance, remote control and monitoring if required.

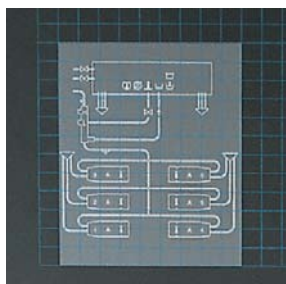

### ▼ Service-friendly

The large and fully removable access door at the front of the machine provides easy access for servicing.



# The Clean Solution

Gerni stationary solutions are incredibly flexible. Through careful planning of the installation, it is possible not only to work directly next to the pressure washer, but also to plan and use a piping installation, allowing one or more users to clean at long distances away from the machine. The pressure washer can thus be stored in a special room, away from processing equipment, or non-authorized people.

The planning of a good installation can give rise to multiple outlets and detergent satellites. Thus, when moving from one cleaning point to another... you simply disconnect the hose and gun and move to the next site... without transporting an unwieldy pressure washer with you.

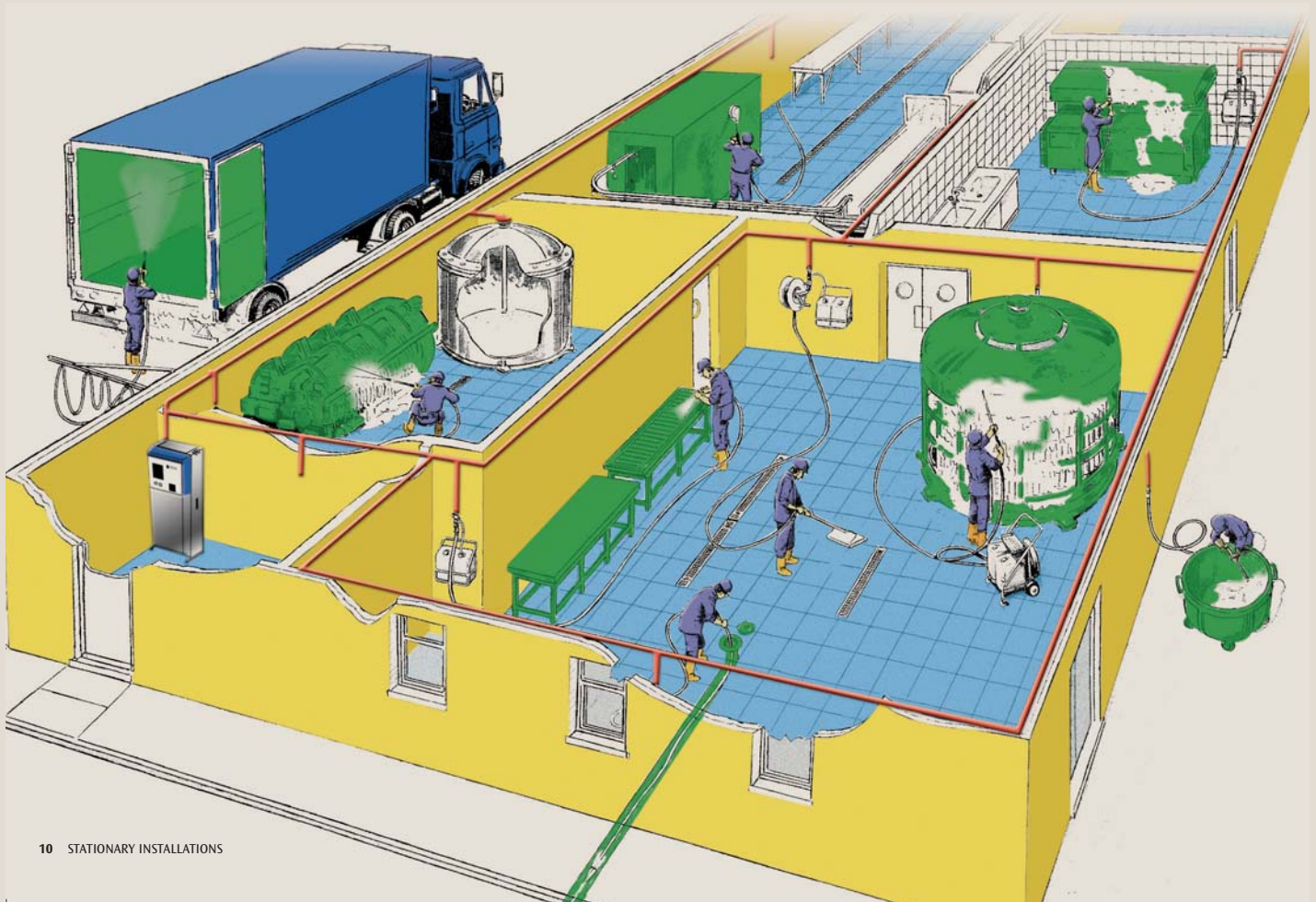

# Increased Flexibility with Gerni Options



The Gerni DUO and ALPHA BOOSTERS can be equipped with an electronic control board. This gives the possibility to use a wide range of factory-mounted options and equipment such as remote control, coin boxes, pressure relief...

The use of options means that a standard machine is quickly and easily configured to become a customer-specific solution.

Option	Description	DUO BOOSTER EXTENDED	ALPHA BOOSTER 5-27	ALPHA BOOSTER 5-49
High Pressure detergent manual	Injection of detergent under high pressure, manually controlled at the machine	107340903	na	na
1 x detergent, electronic	Injection of 1 x detergent under high pressure controlled by solenoid valve and dosing unit. Detergent can be activated at a remote control unit or coin box. NOTE : For the DUO BOOSTER, the activation of detergent will only lead to the use of 1 of the 2 pumps capacity. For a special solution using 2 pump water capacity and injection of detergent, please request a special project.	107340906	na	na
2 x detergents	Injection of 2 x detergents under high pressure controlled by solenoid valve and dosing unit. Detergent can be activated at a remote control unit or coin box. NOTE ; For the DUO BOOSTER, the activation of detergent will only lead to the use of 1 of the 2 pumps capacity. For a special solution using 2 pump water capacity and injection of detergent, please request a special project.	107340907	107360901*	107360901*
Pressure Relief	If the system is not in use for 10 minutes (or 20 seconds after the system closes down), a valve opens and relieves the pressure in the high pressure piping line. The entire system is free of pressure and must afterwards be started again.	107340902	na	na
Low water security	Pressure switch on water inlet of the stationary unit. Set to 1 bar. Inlet water lower than 1 bar - the motor pump stops avoiding the unit running in "dry" mode.	107340905	na	na
Control kit	Option control kit for detergent, coin box, remote control with ALPHA BOOSTER 5	na	107360902	107360902
Cold Warm switchover	Allows double water inlet (hot and cold) and switchover between sources.	107340916	na	na
Output reduction	Reduction of flow and pressure to a pre-chosen level. It allows increase in the concentration of detergent. The customer can choose % of reduction.	Text order	na	na
Water Inlet security	Comprises of a magnetic valve on the water tap, 5m cable and a 24v, DC plug. If the hose breaks, the valve on the tap closes, preventing water spill.	107340910	na	na
Remote Control boxes	On-Off = 2 buttons On-Off + 1 function (burner or option) = 3 buttons On-Off + 2 functions (burner or option) = 4 buttons On-Off + 3 functions (burner or option) = 5 buttons Mains cut off button	107340911 107340912  107340913 107340914  29277	107340911* 107340912*  107340913* 107340914*  29277*	107340911* 107340912*  107340913* 107340914*  29277*
Coin Boxes	Mechanical, simple on-off, €½ Mechanical, simple on-off, €1 Mechanical, simple on-off, €2 Mechanical, simple on-off, Tokens Mechanical, on-off + 1 detergent, €½ Mechanical, on-off + 1 detergent, €1 Mechanical, on-off + 1 detergent, €2 Mechanical, on-off + 1 detergent, Token Electronic, rotary switch, without LCD Electronic, rotary switch, with LCD	54328 54329 54331 54330 54332 54333 54335 54334 29272 54321	54328* 54329* 54331* 54330* 54332* 54333* 54335* 54334* 29272* 54321*	54328* 54329* 54331* 54330* 54332* 54333* 54335* 54334* 29272* 54321*
Frost protection (lost - requires pressure relief) Standard Deluxe with heater		107370954 107370955	na na	na na

\* Requires Control Kit 107360902

# Installation diagram

## For stationary high pressure systems

### Location of the Gerni Delta Booster

The Gerni DELTA BOOSTER is fitted with vibration absorbing rubber supports, so it may be placed straight on an even surface. The plant must be placed in frost-free premises, where the maximum temperature does not exceed 40°C.

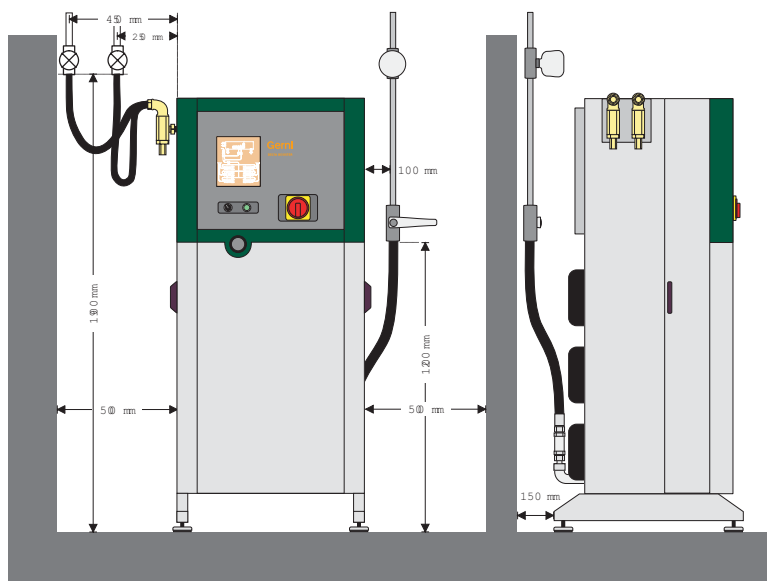

*(Gerni DELTA BOOSTER is used as example in this explanation)*

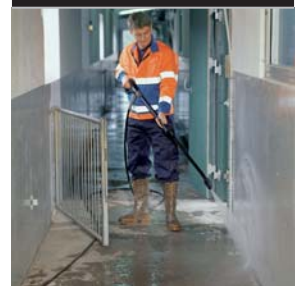

# Piping Installation

Each individual case of piping installation depends on the building, where it is to be located and special requirements, if any. Due regard should be paid to the fact that large pipe dimensions and units are considerably more expensive, and the financial costs of each solution should therefore always be compared to one another.

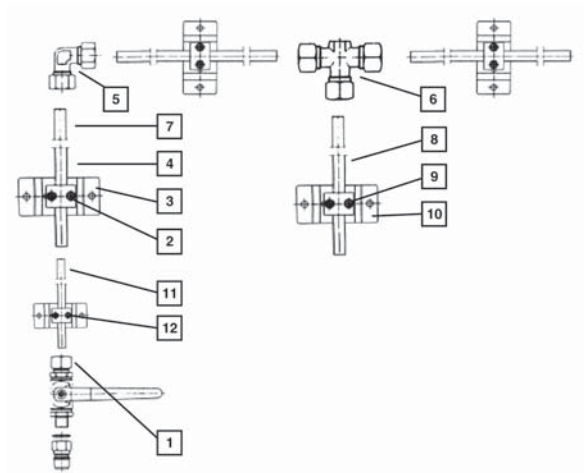

# Accessories, Detergents and Options

## For stationary pressure washers

### The difference between a product and a cleaning solution

The Gerni range of stationary pressure washers can be adapted to each particular situation in order to offer the best possible solution - and guarantee efficient and profitable cleaning for your sites.

### Accessories

Gerni boasts one of the largest ranges of accessories, easing cleaning in difficult places or reducing cleaning time. This range includes :

- Cleaning heads for tanks, barrels and containers
- Hose routing systems
- Cleaning trolley
- Sand and softblasting kits
- Floor cleaning equipment – and much more...

### Schematic diagram: Hose routing system

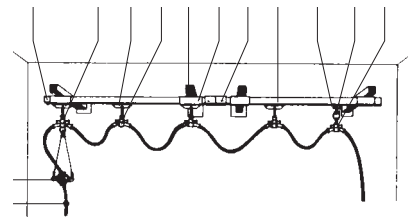

Wall mounting

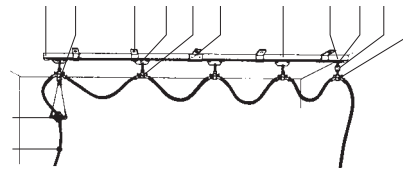

Ceiling mounting



*Cleaning heads:  
The condition for  
excellent cleaning  
results.*

TRK 100/1



TRK 25

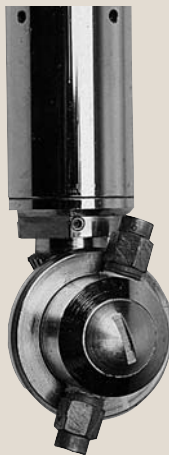

TRK 150



FRK 150



*See our product catalogue for more information.*

# Stationary Hot Water Pressure Washers



## Stationary Unit For Tough No Compromise Cleaning

Hot water stationary unit for permanent placement outside for use in fleet, haulage sectors or in slaughterhouse delivery yards.

The TRUCK BOOSTER is a simple, robust and corrosion proof hot water stationary unit designed for permanent external placement in a forecourt. This enables constant cleaning of trucks, vans, commercial and construction vehicles and equipment. Simple to use, access to internal components can be locked.

- Stainless steel robust design protects against corrosion
- EcoPower boiler for reduced fuel consumption
- Silent Power, low noise level with 1450 rpm motor pump units
- Simple control panel with only 4 buttons
- ERGO 3000 accessories for added user friendliness
- Available in both single phase and three phase formats.

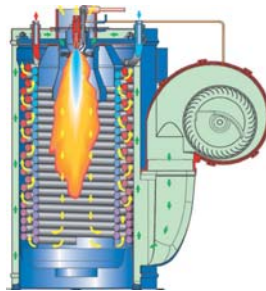

*EcoPower Boiler:  
Efficiency >92%.  
Major Fuel cost and  
service cost saving.*

### Technical data

		<b>TRUCK BOOSTER 7-63 D 107370890</b>
Pressure	bar/Mpa	175/17.5
Cleaning Impact	kg/force	6.3
Water flow	Q <sub>iec</sub>	l/h 1170
Water flow	Q <sub>max</sub>	l/h 1260
Max Inlet Temperature	°C	40
Voltage	V/~/Hz/A	400/3/50/16
Pump	rpm	1450
Water temperature (Water/steam)	°C	90/140
Weight	kg	285
Dimensions L x W x H		1025 x 715 x 1670
Detergent Tank	L	2 x 25

### Standard equipment

Hose	10 m
Ergo Gun	● Ergo 3000
Repair Kit	●
Tornado Lance	●
Tornado Kit	●



◀ Gerni TRUCK BOOSTER

rs



### Think out of the box

The basic machine can be modified to suit almost any application with the addition of some key accessories and the expertise of the Gerni Project Team.

#### ► Assisted Boom

Enables ease of movement around the vehicle during cleaning.



#### ► Hose Reels

Range of hose reels available including trolley, wall mounted or on board options.



#### ► Remote Control Box

Four buttons  
Stop / On / Hot Water / Detergent.

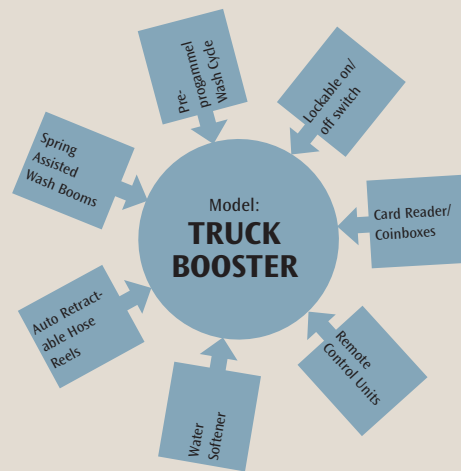

#### ▼ Service Friendly

Cabinet door ensures easy access to all components for servicing and maintenance.





## Professional stationary pressure washers The performance, the cleanliness, the advantages

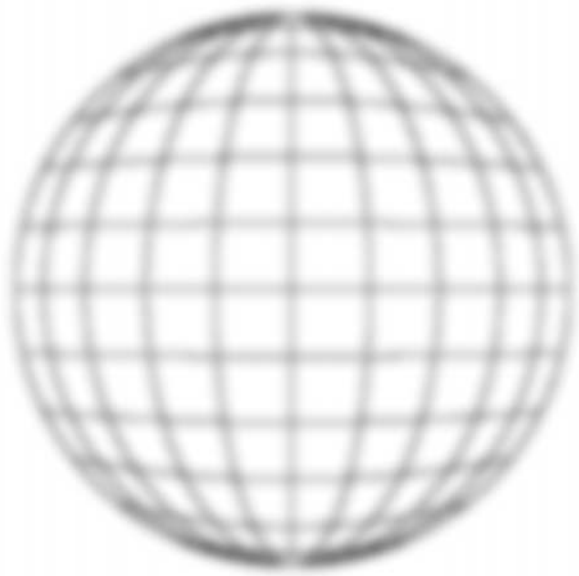

You will obtain the best possible cleaning solution for your installation thanks to...

- Our expertise in planning and installing units
- The most reliable and durable solutions on the market
- A range of options and accessories that enable you to customize the cleaning equipment to satisfy each of your specific needs



Nilfisk-Advance A/S of which Gerni is a division is the number one professional cleaning equipment company with a turnover of 630 million € and 3800 employees. We are located in all main European countries, Australia, US and Asia with our headquarters in Denmark and production facilities in Germany, Denmark, Hungary, Singapore, China, Italy and the US.

We supply quality high pressure washers to agriculture, automotive and industrial companies, cleaning contractors and private consumers.

Gerni is a product driven company with focus on innovation and growth. We believe in developing and maintaining long lasting relationships with our customers, suppliers and employees.

*No claims can be made on the basis of information or illustrations contained in this catalogue. Subject to alteration of technical data, design and equipment.*

Distributed by



Aus Waterblasters  
9 Deebing Street  
West Ipswich QLD 4305  
Ph: 07 3812 1112

Email: [info@auswaterblasters.com.au](mailto:info@auswaterblasters.com.au)

**Gerni**  
- danish cleaning power